



Inspection Division

2010

SCREENED OR COVERED PORCH

PLAN CHECKLIST

ONE & TWO-FAMILY DWELLINGS

ALL permit applications must include:

- \$60 Plan Review Fee
- 1 Copy of the Permit Application
- 2 Sets of Building Plans
- 2 Plot Plans (8½" x 11" or 8½" x 14" only)
- Completed Screened or Covered Porch Checklist (this form)
- 1 Copy of Workers Compensation Compliance Verification
- Wake Co Approval Required if on Well or Septic System

Project Address _____ or Lot/Subdivision _____

To ensure your plan package is complete, confirm that all boxes above and below are checked and all the information requested has been provided.

- 1) **Plot Plan** (Must show the building structure outline, decks, porches, easements, cantilevers, mechanical equipment, electrical panels/service equipment; and indicate their distances to property lines.)
 - (A) Electrical panel/service equipment is not located within the footprint of the porch
 - (B) Mechanical equipment/venting systems are not located within the footprint of the porch

- 2) **Accessory Structure Permit Application** (Must be complete including an authorized signature)

- 3) **General Information**
 - (A) Plans must be drawn to scale (1/4" = 1')
 - (B) Plans must include the name and address of the person responsible for the design

- 4) **Foundation and Floor Plan**
 - (A) Masonry. Continuous masonry wall installed on a continuous concrete footing (provide section).
 - (B) Deck Plan (Provide if the deck portion is new or existing)
 - (C) Plan (Top) View. Include all necessary structural details identifying the following:
 - Footing sizes (thickness, width, and depth) and locations of each footing
 - Girder size, type of material, and locations of each utilized
 - Floor joist size, type of material, spacing, and direction of span
 - Dimensions between supports of all structural members
 - Treated floor decking material per Appendix M, 6 (i.e. 5/4 x 6, or 2 x 6 S4S)
 - (D) Elevation drawings and construction details provided as necessary for clarification

- 5) **Roof/Ceiling Plan** (Plan view indicating structural members and the locations of their bearing points and components)

Choose roof/ceiling type being utilized (A, B, C, or D):

 - (A) Conventionally ("Stick") Framed Roof (i.e. gable, shed, hip)

Indicate rafter size, type of material, spacing, and direction of span. Roofs with opposing rafters (gable or hip) require collar ties spaced at 48" on center and ceiling joists or rafter ties spaced at 48" o.c.
 - (B) "Cathedral" Roof/Ceiling with a Structural Ridge

Indicate rafter size, type of material, spacing, and direction of span. The structural ridge must be supported directly to a foundation or footing. The structural ridge must be sized for the imposed load according to the Residential Load Estimating Tables or per the published span tables of engineered lumber (provide a copy of the span chart for the engineered beam specified).

5) **Roof Plan Continued**

- (C) Truss Roof

Include the signed and sealed truss detail (profile) sheet for each truss utilized

- (D) **Ceiling Framing**

Indicate the size, type of material, spacing, maximum span, and type of ceiling covering.

6) **Side and Rear Elevations**

- (A) Header locations, size, type of material, and maximum span (distances between supports)

- (B) Locations of header supports (include dimensions)

- (C) Ceiling joists where applicable

- (D) Proposed roof slope

7) **Engineering** (required for, but not limited to the following):

- Deck floor system supported by a cantilever (i.e. bay window)

- Girders cantilevered beyond the post supports more than 6" which are supporting floor load only

- Point loads not supported directly to a foundation or footing

- The upper end of a roof/ceiling system supported to the cantilevered 2nd floor system of the dwelling

- Roof and/or ceiling structure supported by a cantilevered floor system of a deck

- Roof structure supported by a girder that is cantilevered beyond the post support

- Roof structure supported to or by any structural member not addressed by the NC Building Code

- Wood floor system supporting a spa or a hot tub

- Wood floor system designed for loads greater than 40 lbs per sf live load or 10 lbs per sf dead load

- Foundation for a covered deck enclosed by glazing (sunroom)

Electrical Systems (permit is required for new electrical work)

(A) One GFCI receptacle, accessible from grade, is required at the front and rear of the dwelling. If new work makes an existing receptacle inaccessible from grade, an additional receptacle must be added.

(B) One GFCI receptacle within the perimeter of the porch when accessible from the dwelling unit.

(C) New electrical work for receptacles, lights, fans, etc. requires a permit prior to starting the work.

(D) Lighting of exits is required and may necessitate the addition of lighting outlets.

Sample Screened or Covered Porch Plan is attached (page 3 and 4)

To be used as a reference only (your own 1/4" = 1' scaled plan must be provided)

Required Inspections (call 249-3388 to schedule)

(A) Footing Inspection (new and or existing footings)

(B) Floor Joists Inspection (when floor joists are closer than 24" to the ground, prior to installing decking)

(C) Rough In. Required before any work is concealed.

(D) Final Inspection. All work must be complete and visible for inspection.

Designer:
John Q. Public
100 North Main Street
Apex, NC

Sample Screen Porch Plan (Shed Roof)

This sample drawing is an example only. A specific plan for your project, drawn to scale, and including all information on the checklist must be provided.

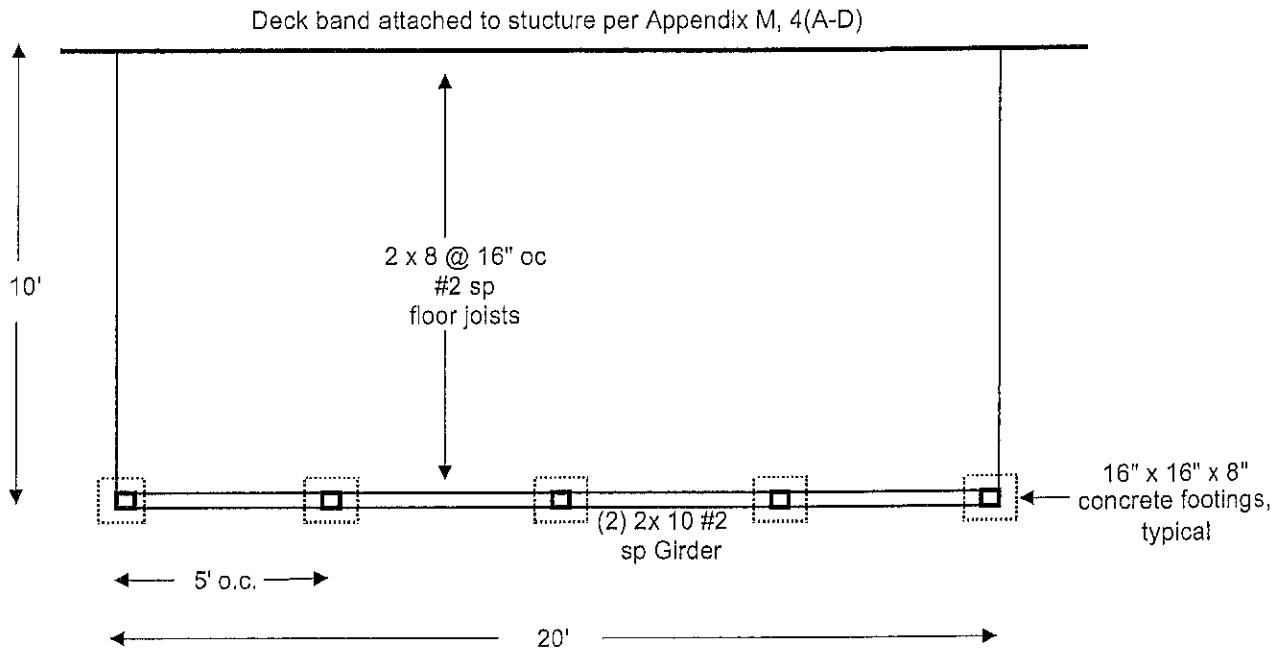

DECK PLAN

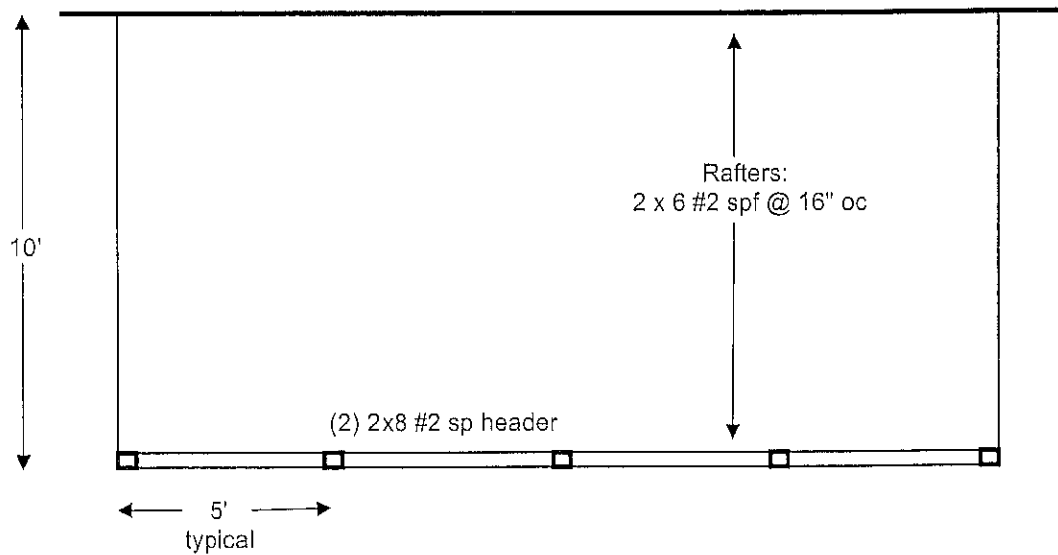

ROOF PLAN

Scale: 1/4" = 1'

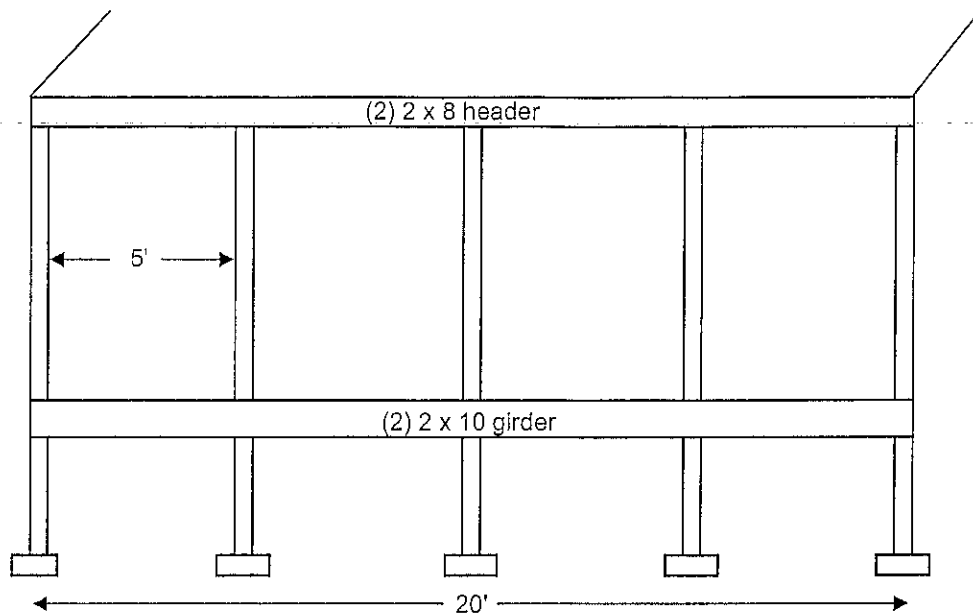

REAR ELEVATION

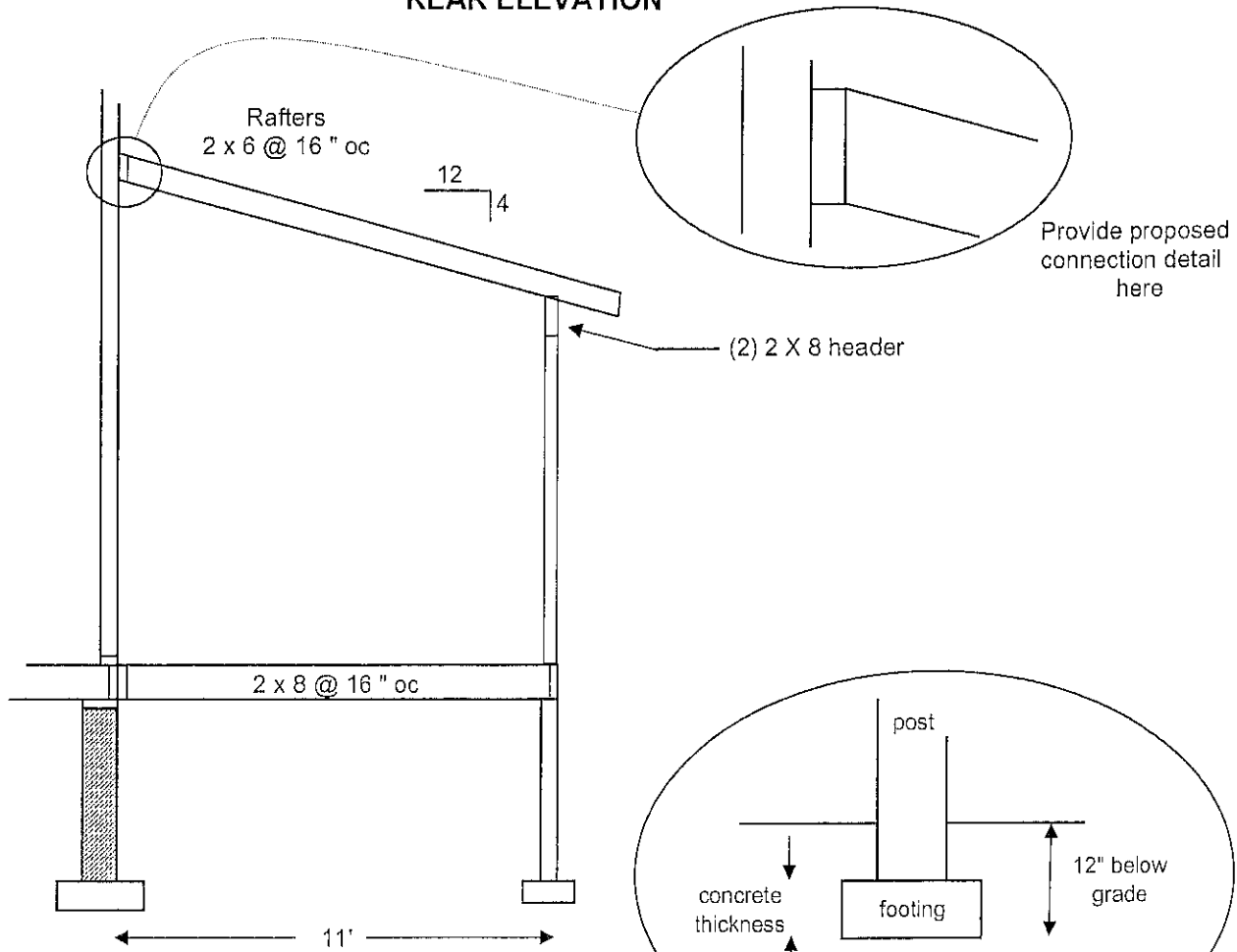

SIDE ELEVATION, TYPICAL

TYPICAL FOOTING DETAIL, N.T.S.